

**ТЕХНОГРАД**

Сохраняя баланс интересов



# DOORHAN®



## Привод для откатных ворот SLIDING-500PRO/ 800PRO/500-24V

## SLIDING-500PRO/ 800PRO/500-24V Operator

Инструкция  
Installation Instructions

Общая информация General information	2
Установка зубчатой рейки Gear rack installation	4
Установка привода Operator Installation	5
Установка магнитов Magnets Installation	8
Работа расцепителя Release operation	9

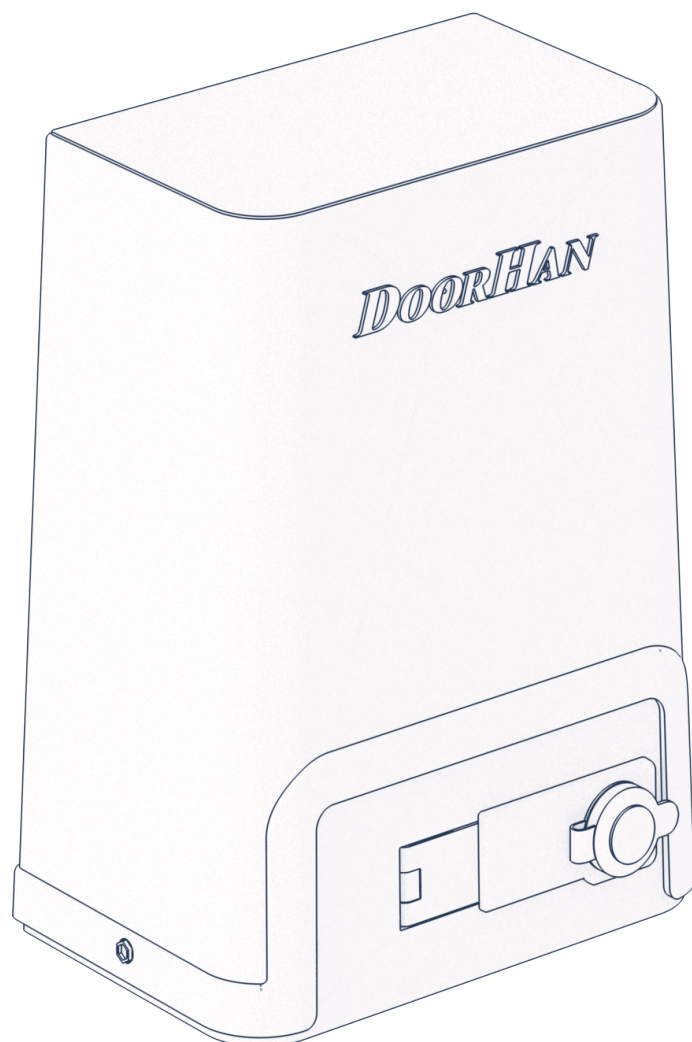

## ОБЩАЯ ИНФОРМАЦИЯ / GENERAL INFORMATION

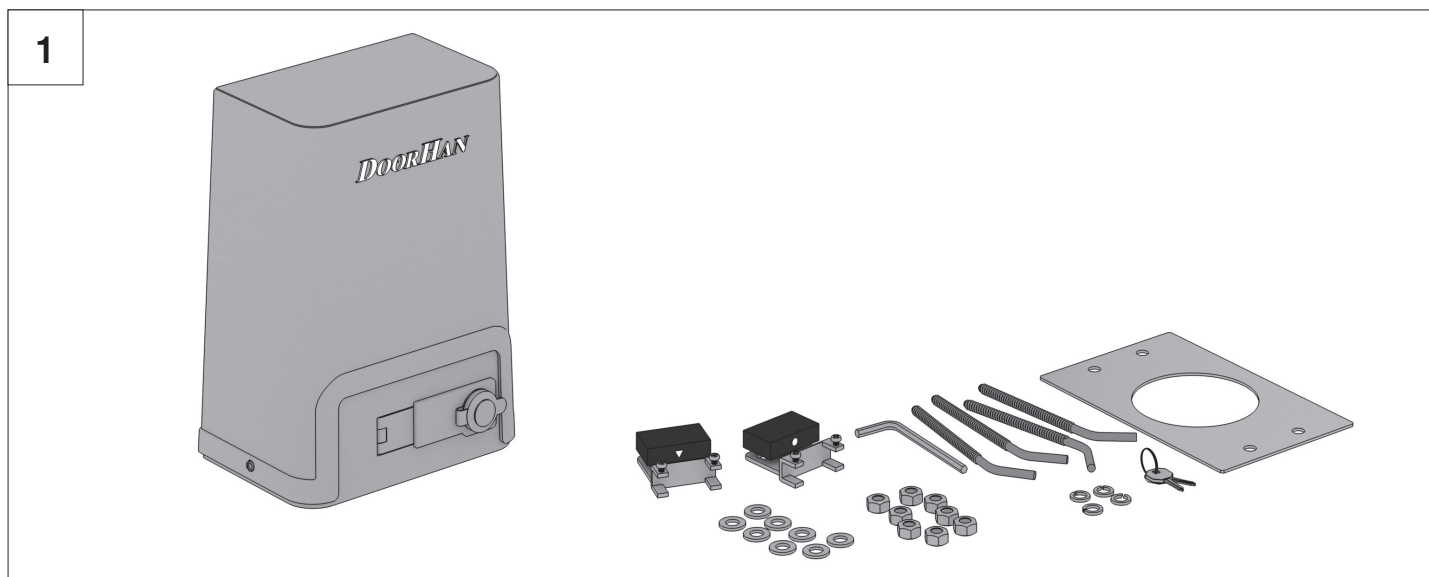

Технические характеристики / Specifications	Sliding-500PRO	Sliding-800PRO	Sliding-500-24V
Питающее напряжение, В/Гц / Supply voltage, V/Hz	220–240/50, 60	220–240/50, 60	220–240/50, 60
Ток потребления, А / Current consumption, A	2,1	2,1	2,0
Мощность, Вт / Power, W	460	460	440
Передаточное отношение редуктора / Gear ratio	1:32	1:32	1:32
Максимальный крутящий момент, Н·м / Maximum torque, N·m	16	20	16
Максимальный вес ворот, кг / Maximum gate weight, kg	500	800	500
Скорость ворот, м/мин / Gate opening speed, m/min	10	12	10–17
Шестерня / Gear	Z16	Z16	Z16
Рейка, мм / Gear rack length, mm	M4	M4	M4
Концевые выключатели / Limit switches	магнитные / magnetic	магнитные / magnetic	магнитные / magnetic
Термозащита, °C / Thermal protection, °C	125	125	—
Интенсивность, % / Intensity, %	50	50	100
Диапазон рабочих температур, °C / Operating temperature, °C	-20...+55	-20...+55	-20...+55
Емкость конденсатора, мкФ / Condenser capacity, mkF	10 ± 5%	10 ± 5%	—
Класс защиты / Protection class	IP54	IP54	IP54

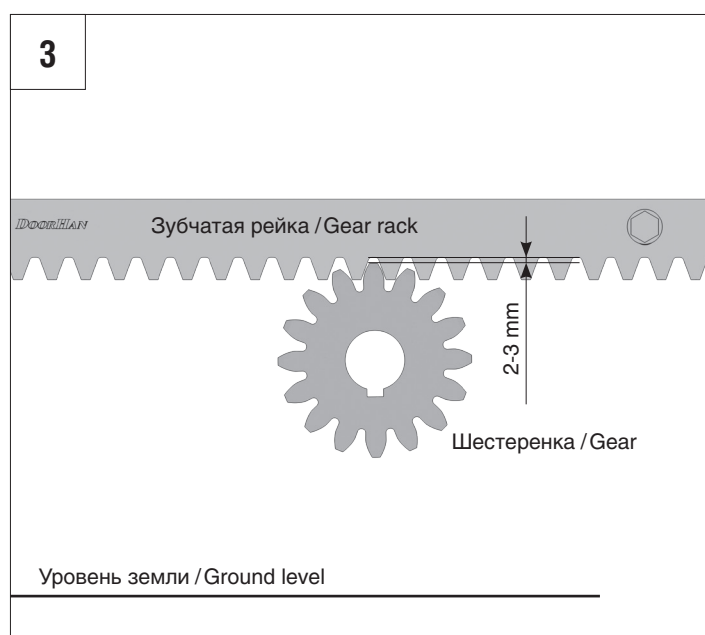
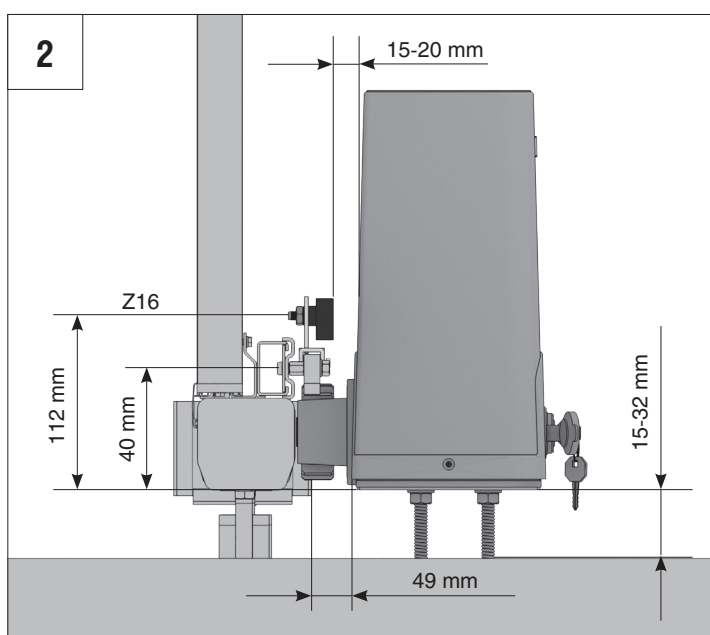

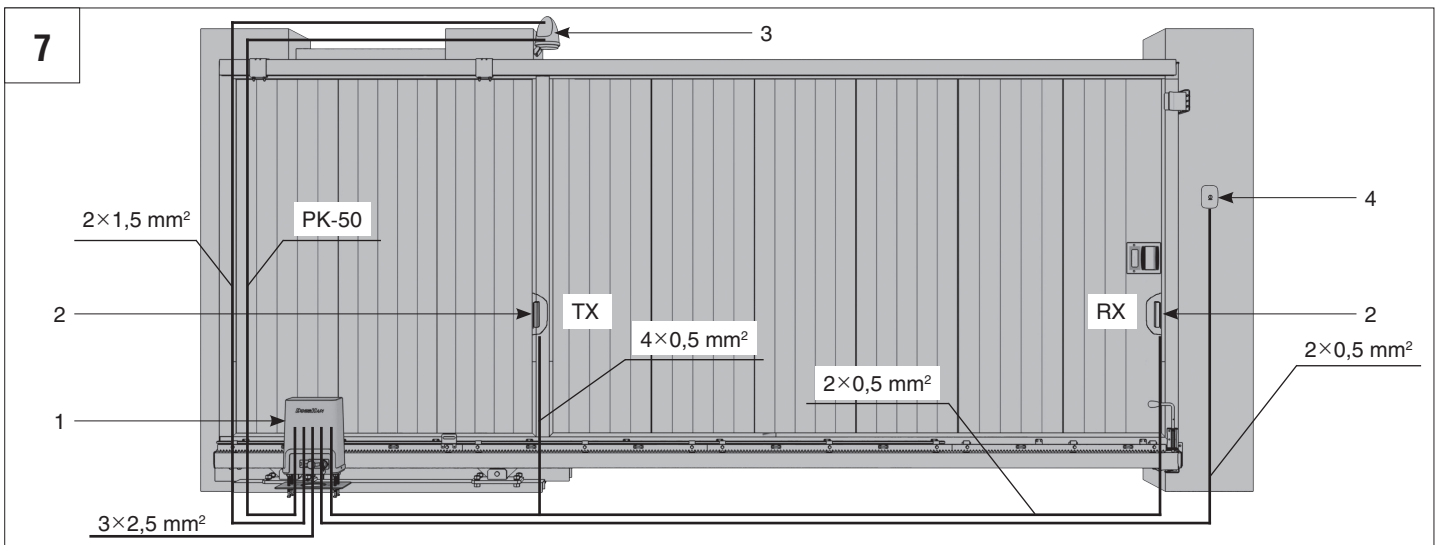
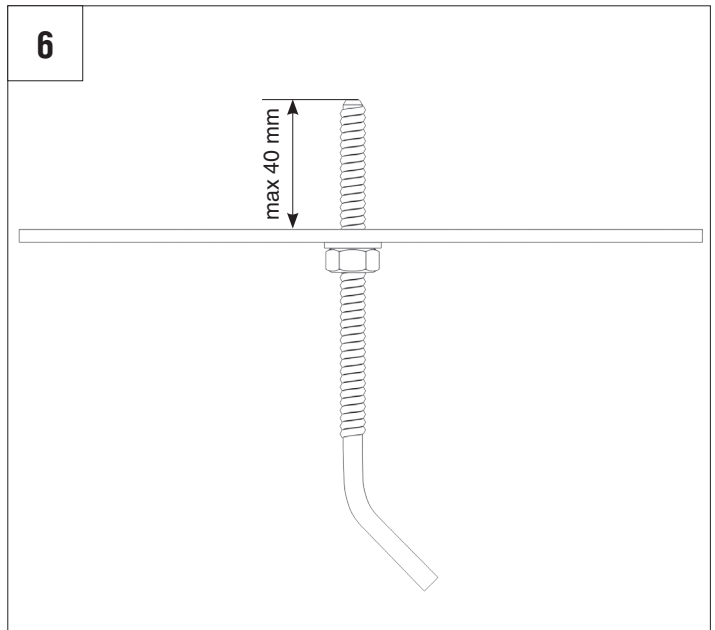
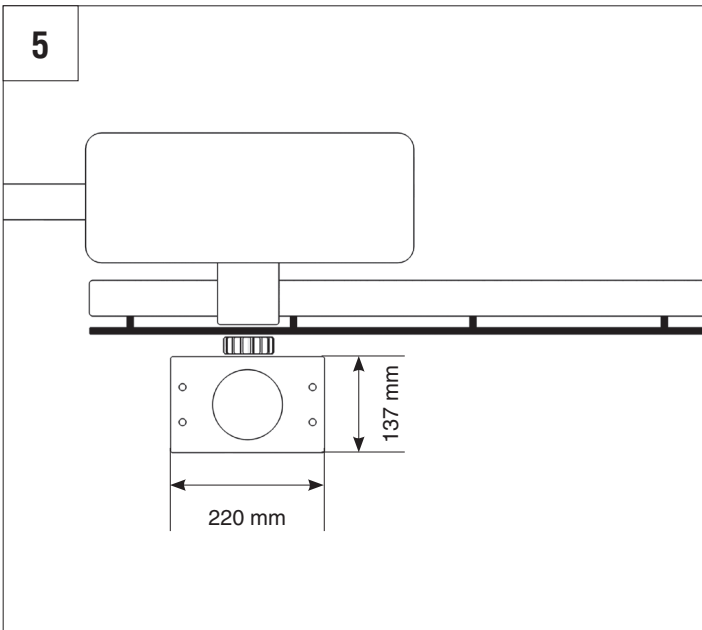
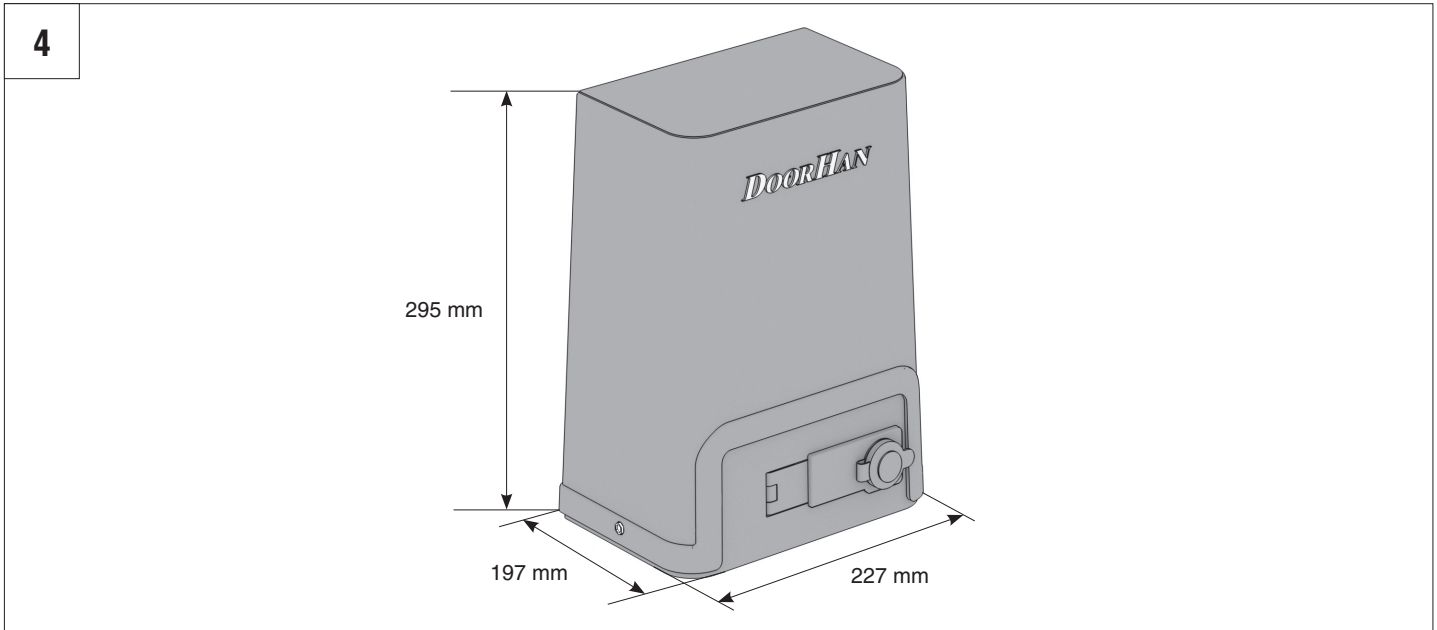

1. Привод с блоком управления/Operator with control unit    3. Сигнальная лампа/Signal lamp  
 2. Фотозлементы/Photocells    4. Ключ-кнопка/Key-button

УСТАНОВКА ЗУБЧАТОЙ РЕЙКИ / GEAR RACK INSTALLATION

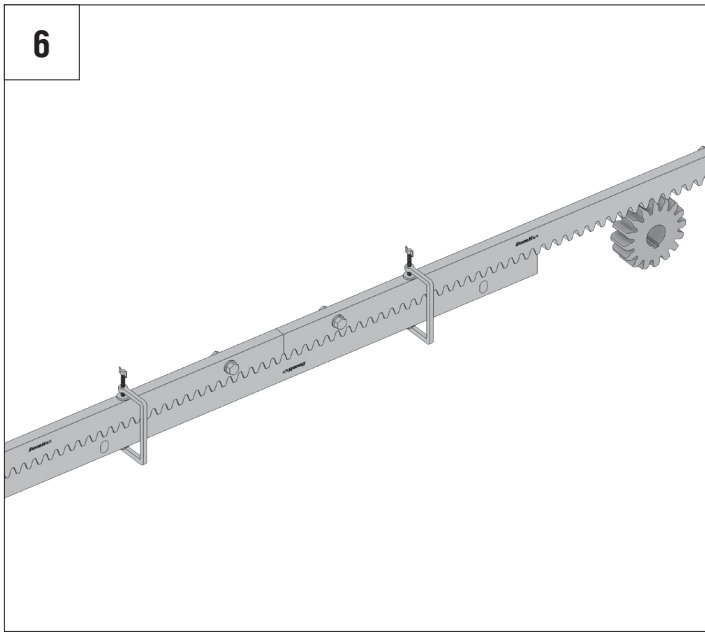
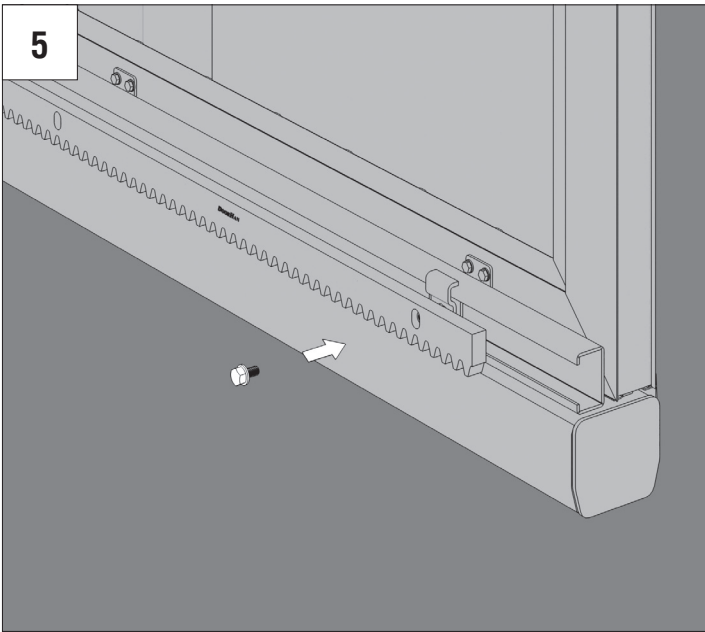
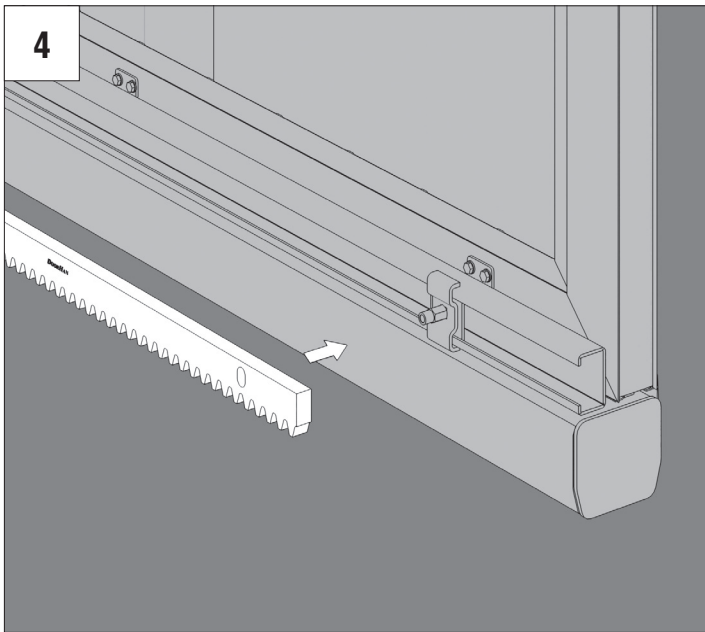
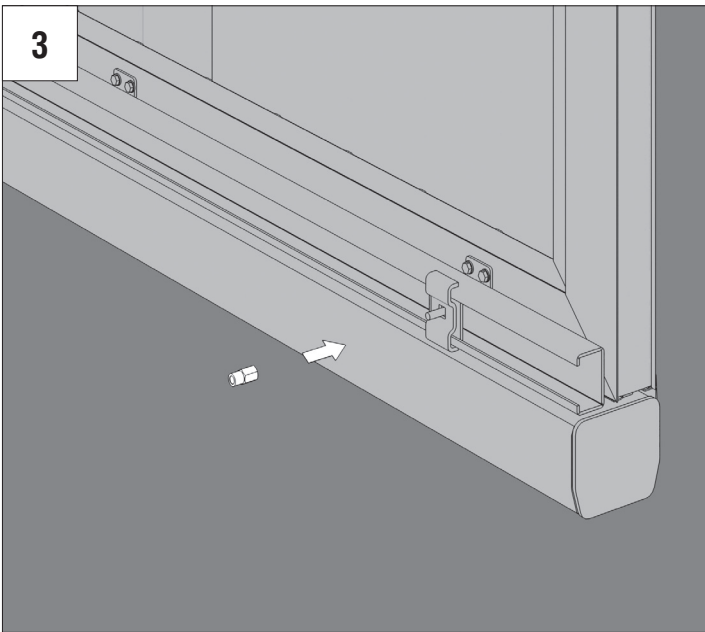
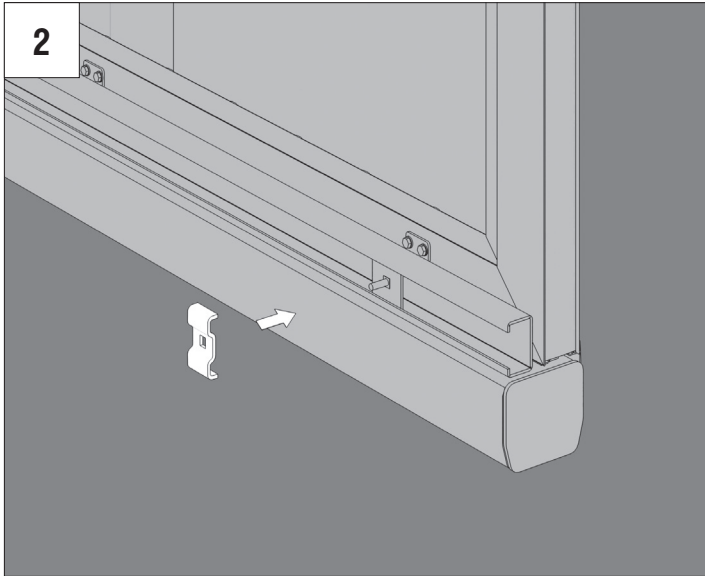
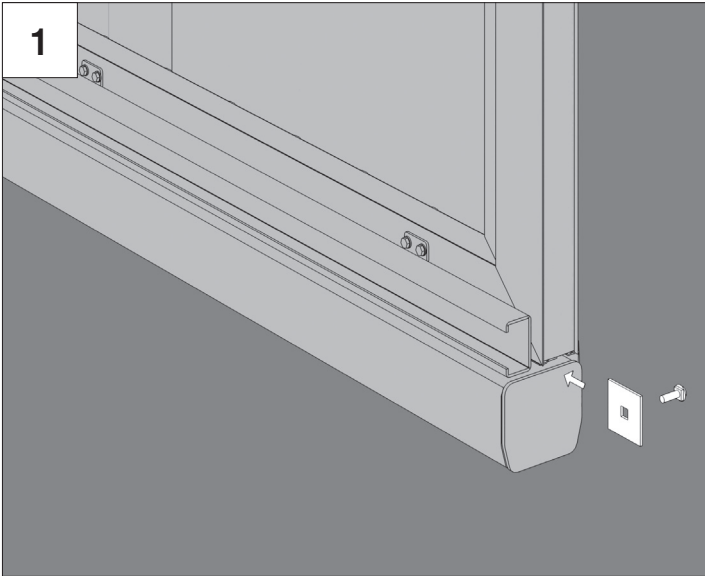

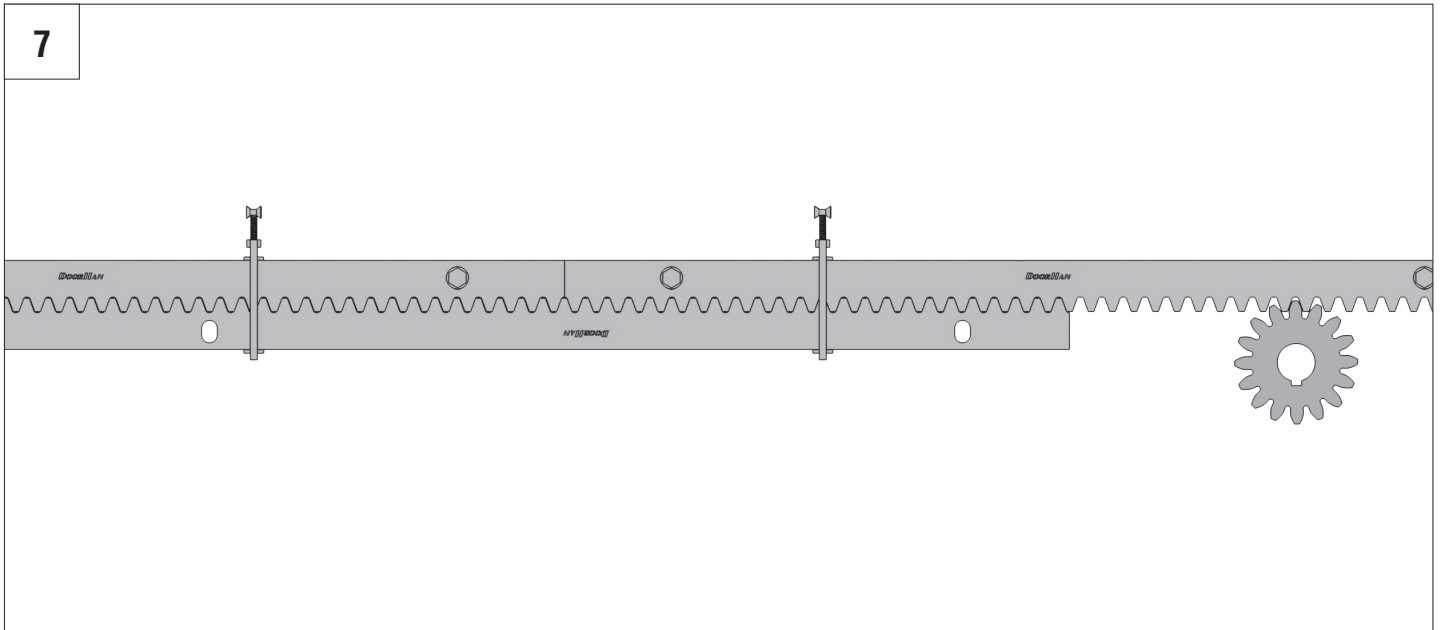

**УСТАНОВКА ПРИВОДА / OPERATOR INSTALLATION**

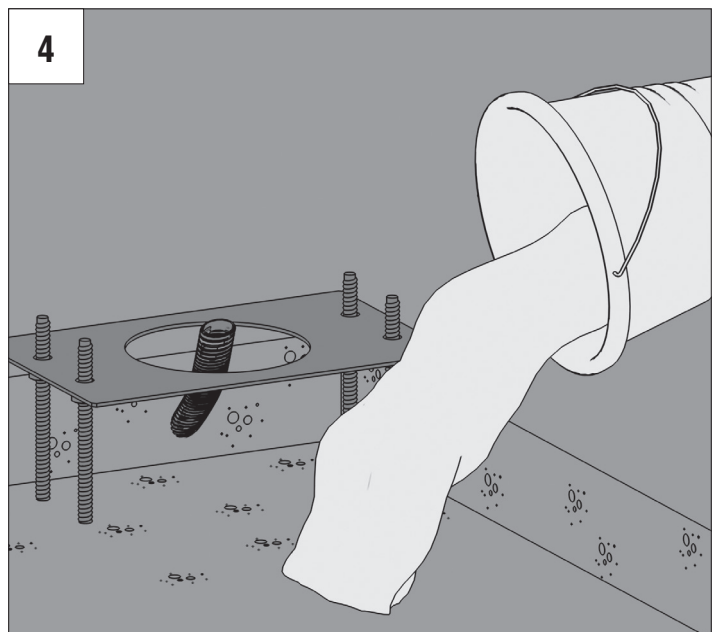
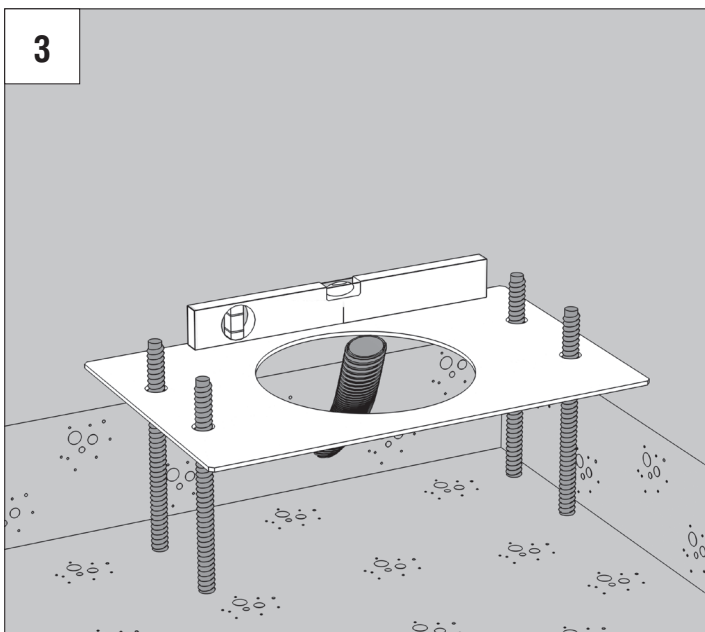
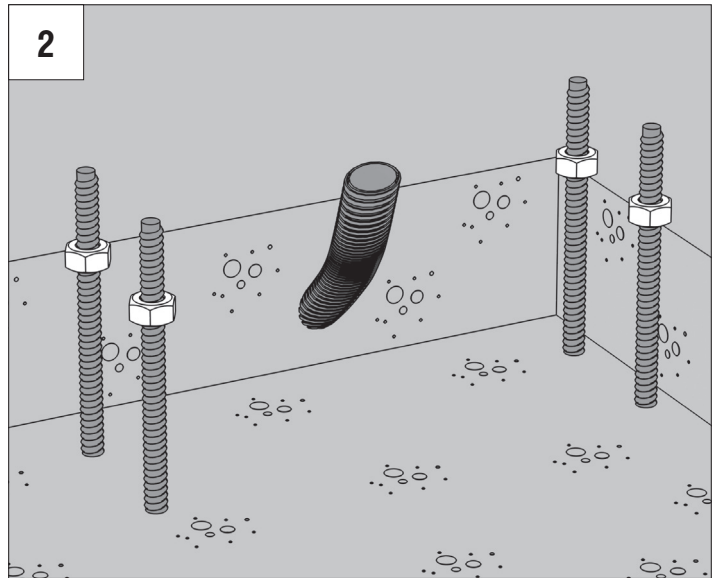
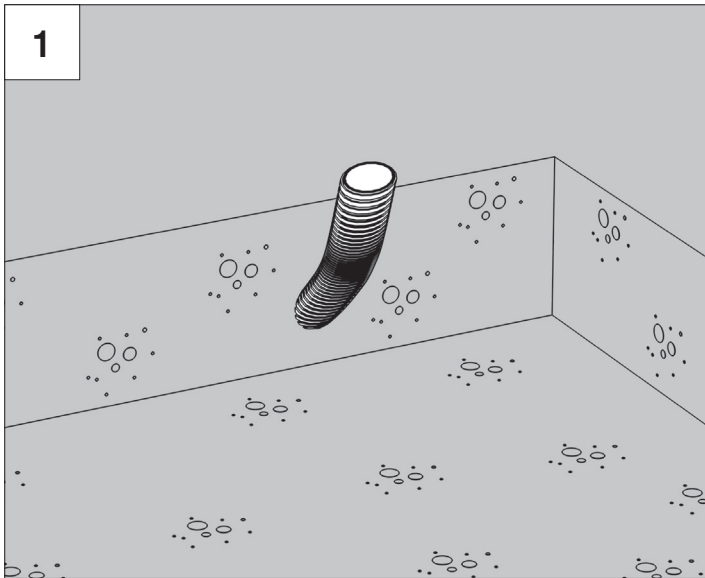

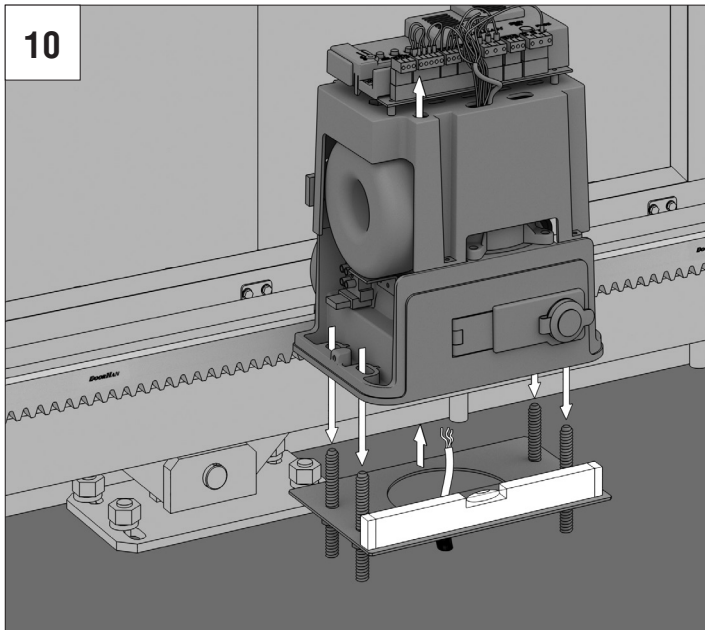
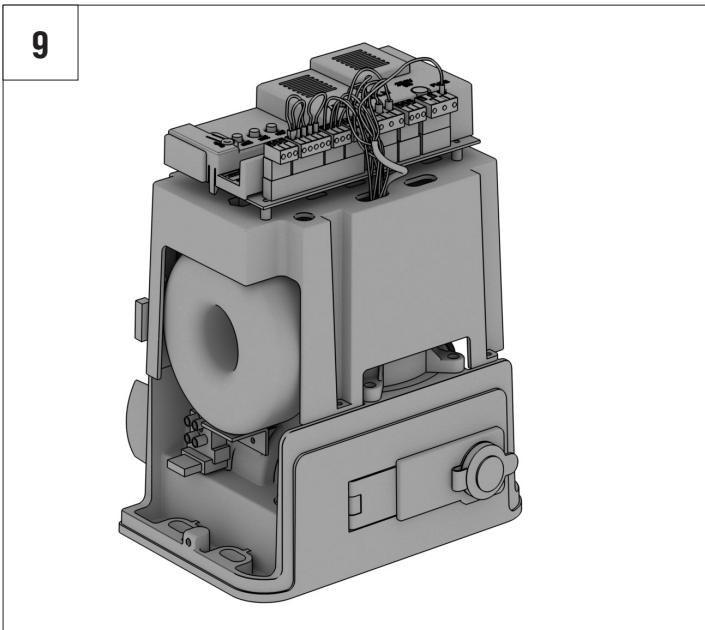
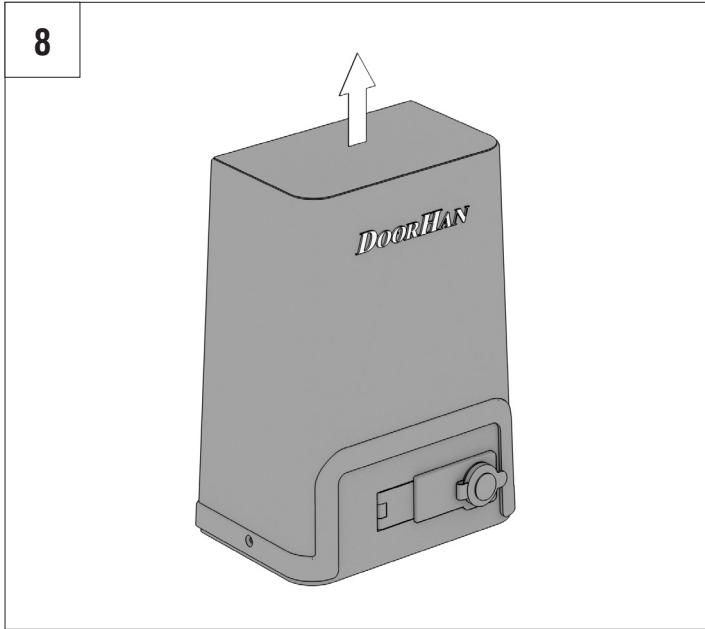
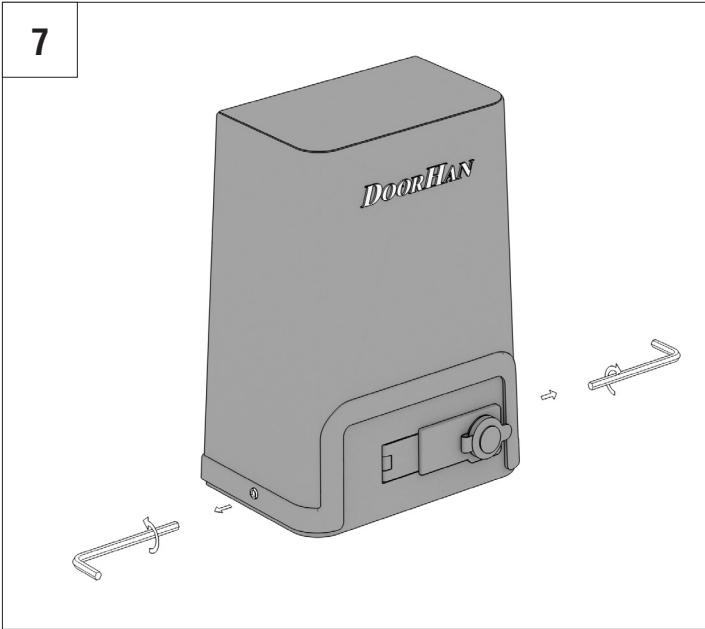
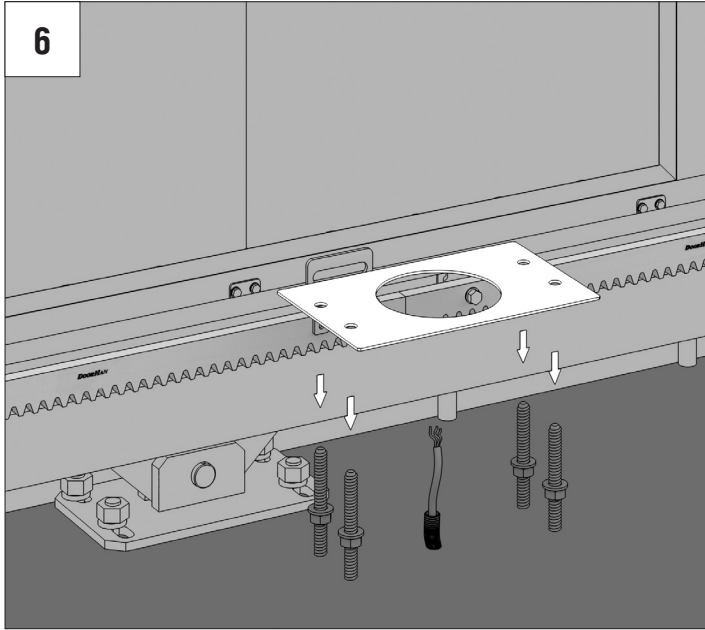
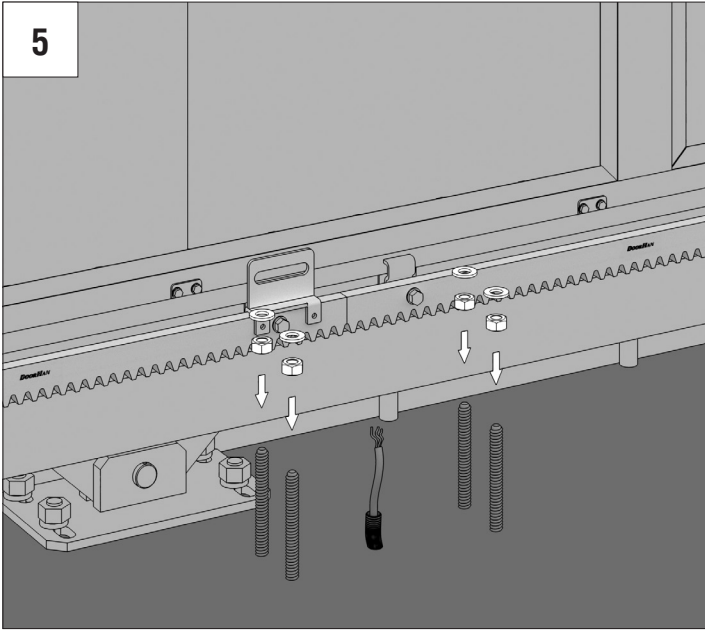

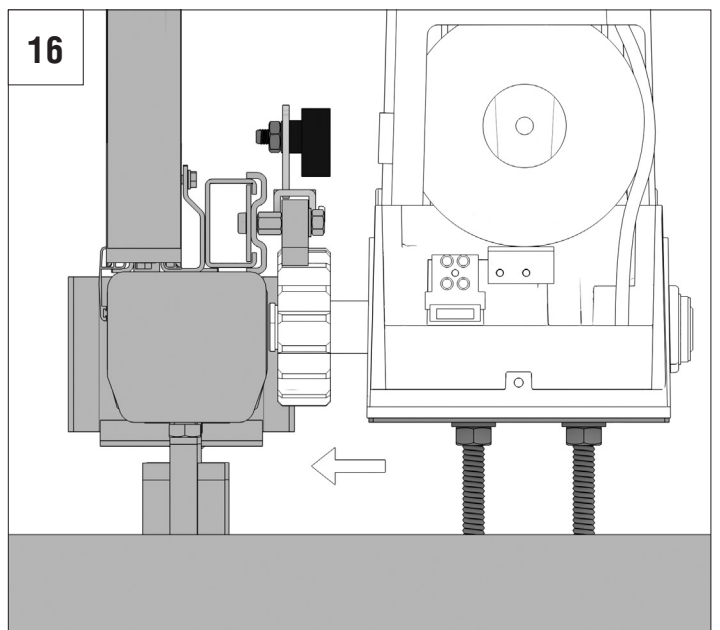
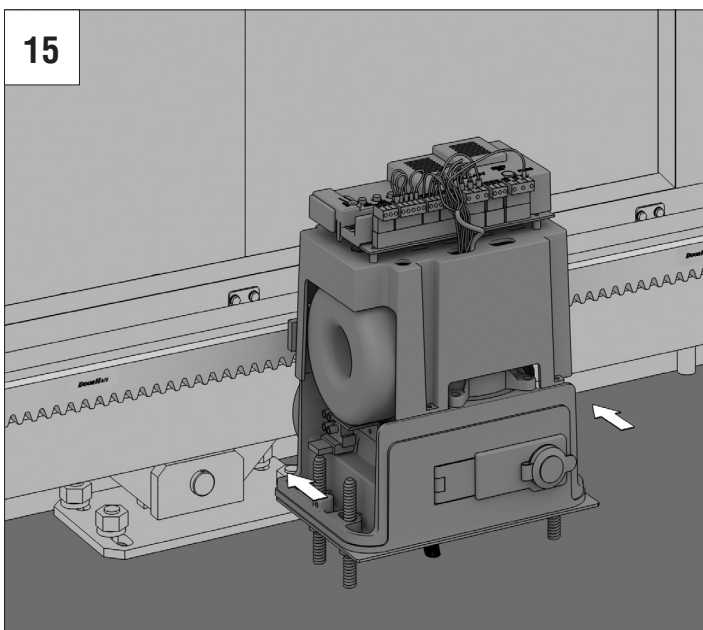
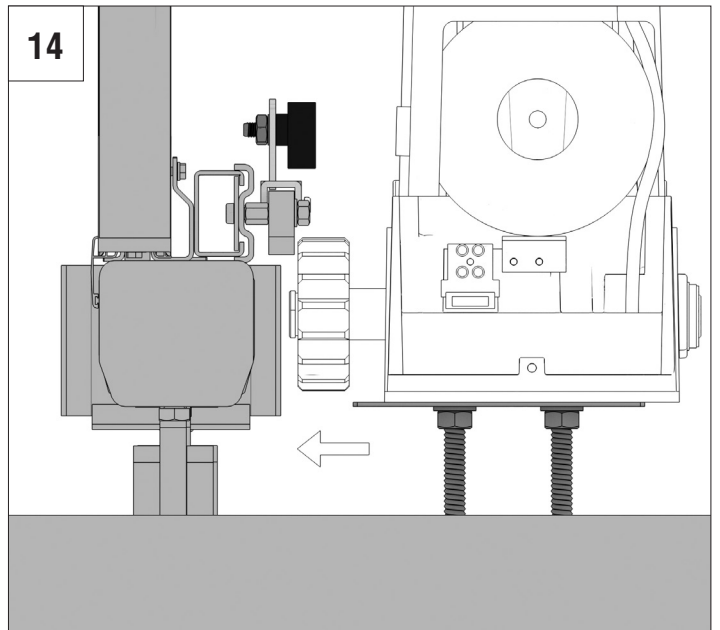
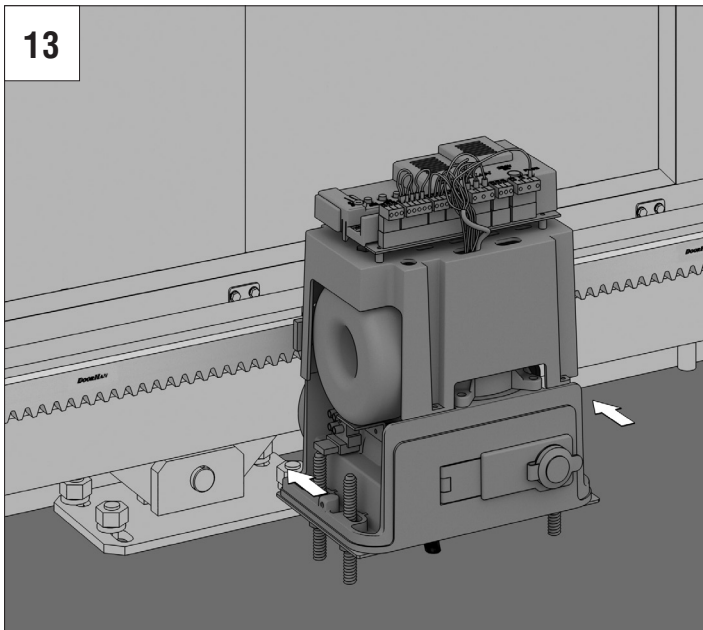
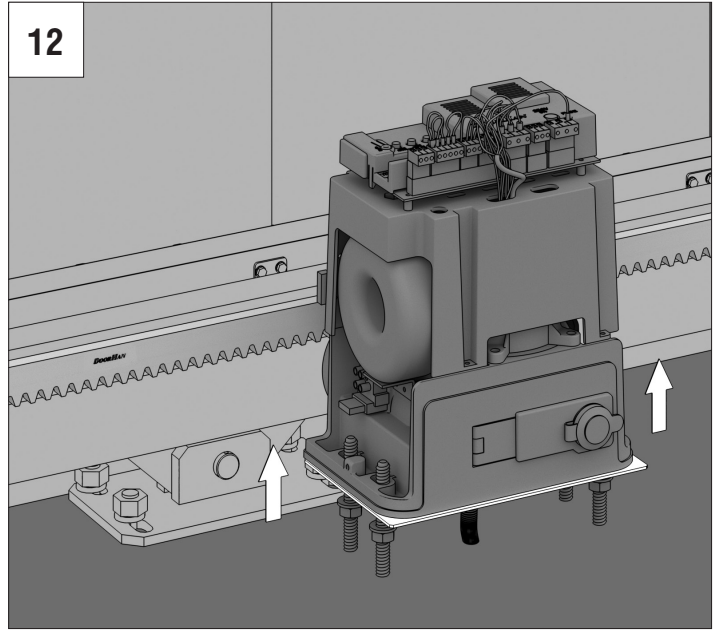
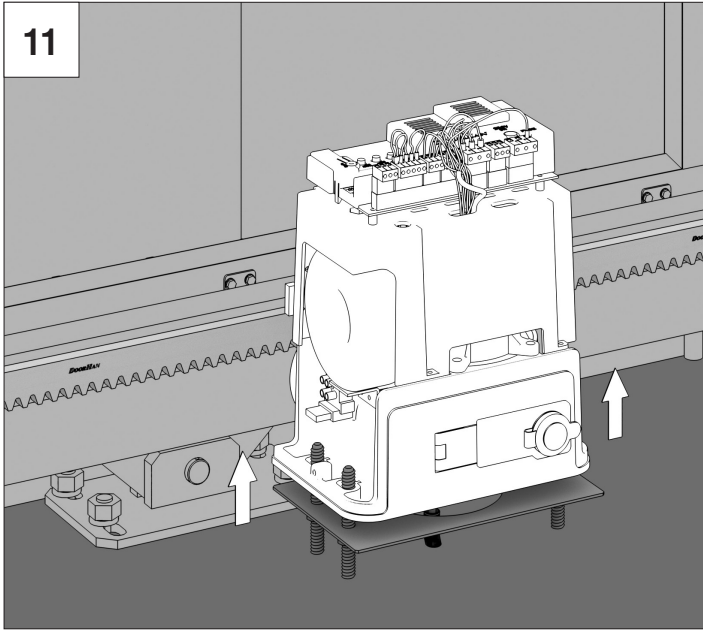



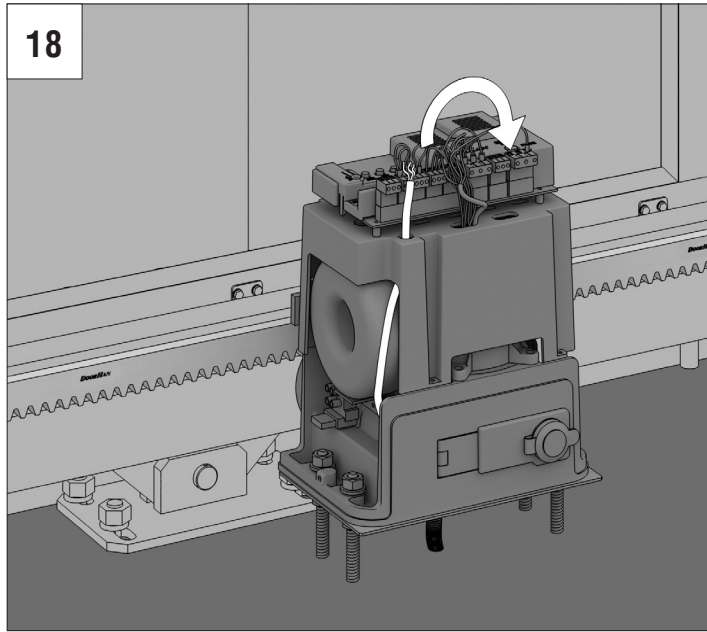
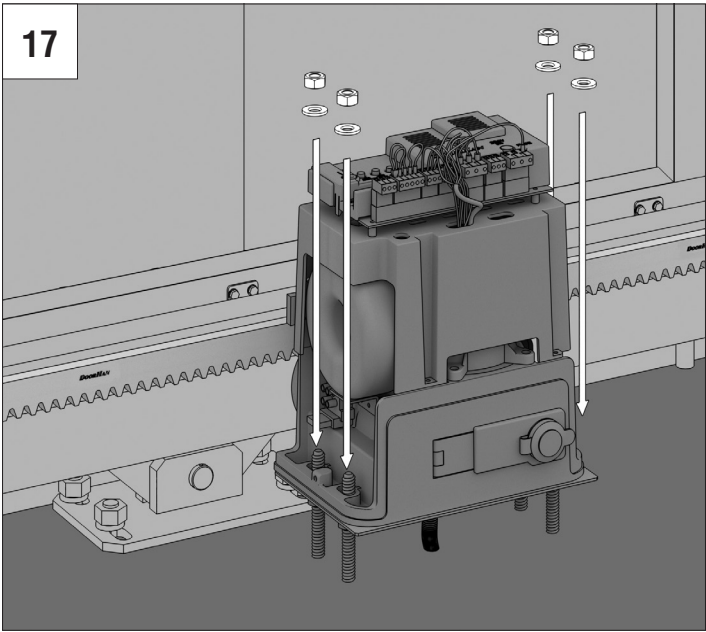

**УСТАНОВКА МАГНИТОВ / MAGNETS INSTALLATION**

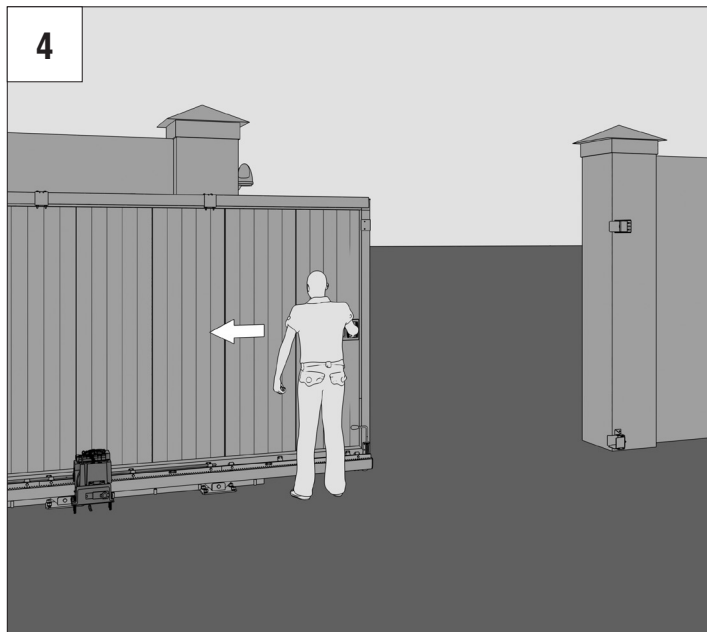
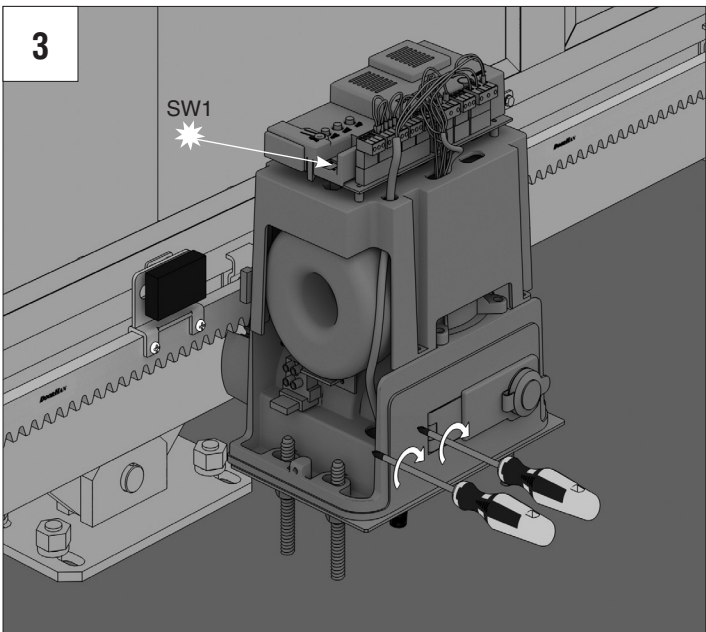
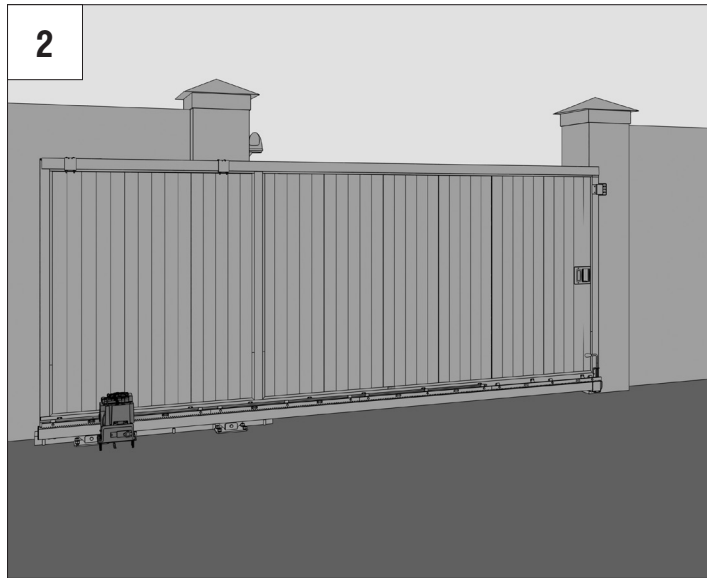
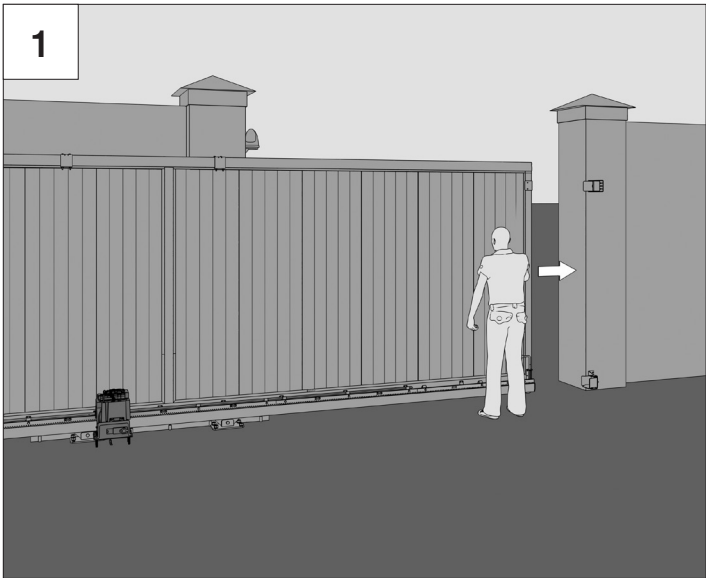

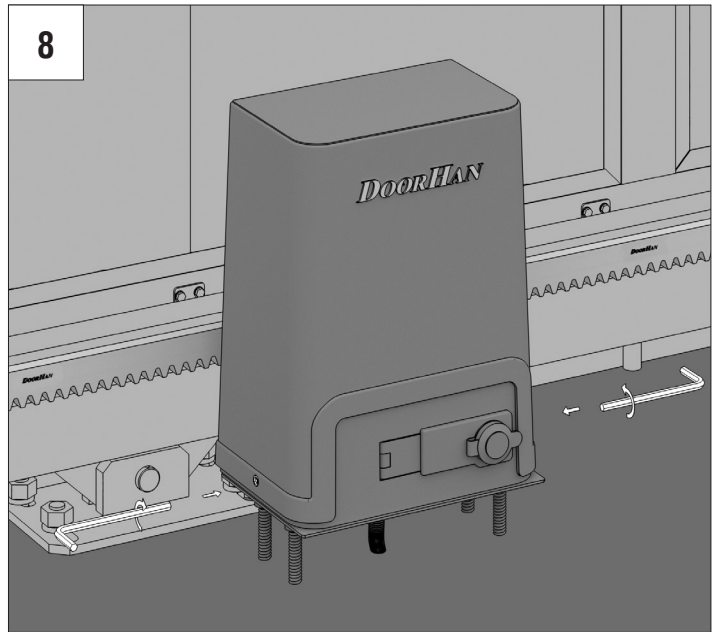
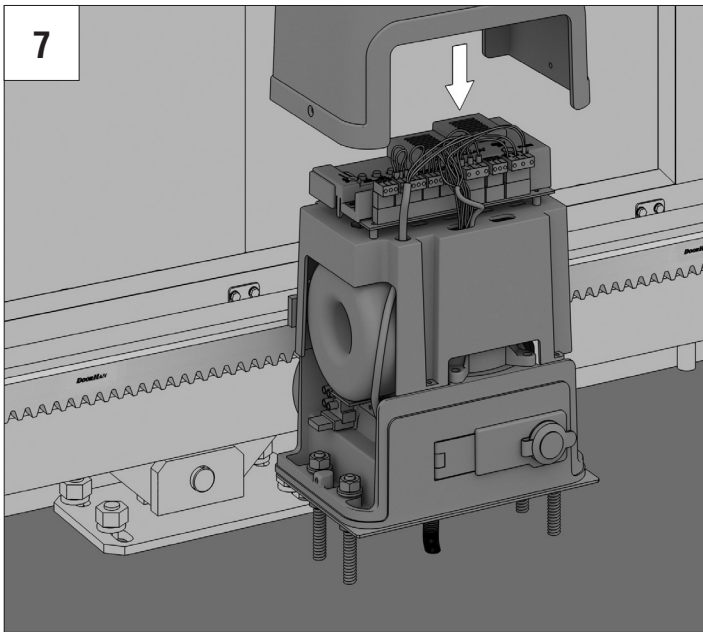
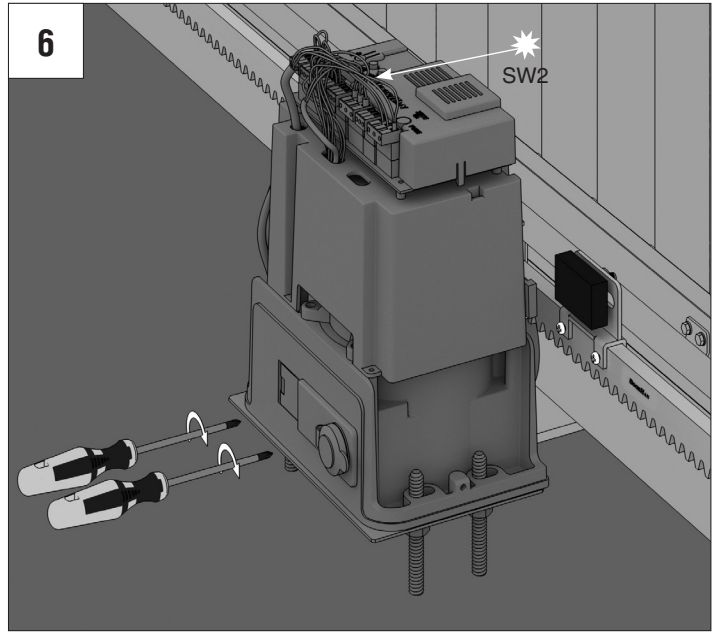
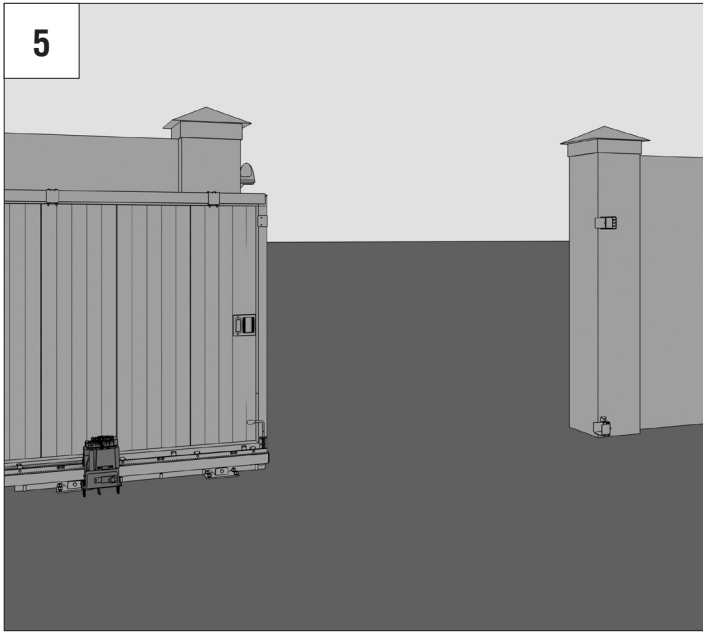

**РАБОТА РАСЦЕПИТЕЛЯ / RELEASE OPERATION**

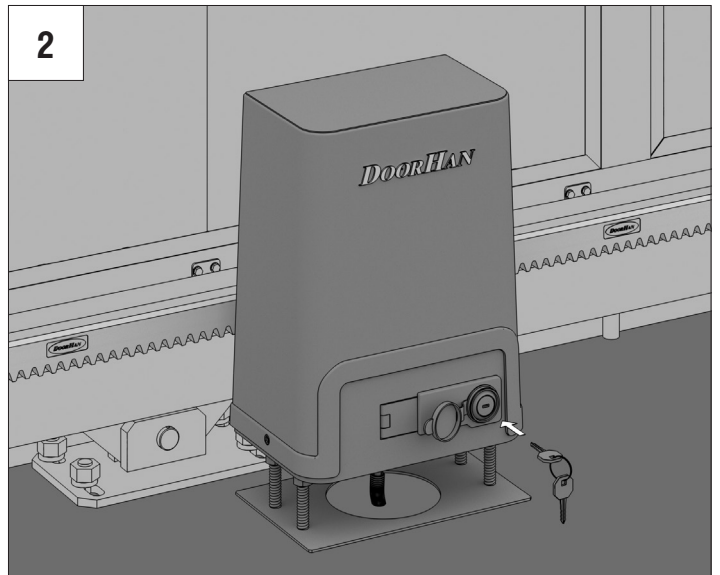
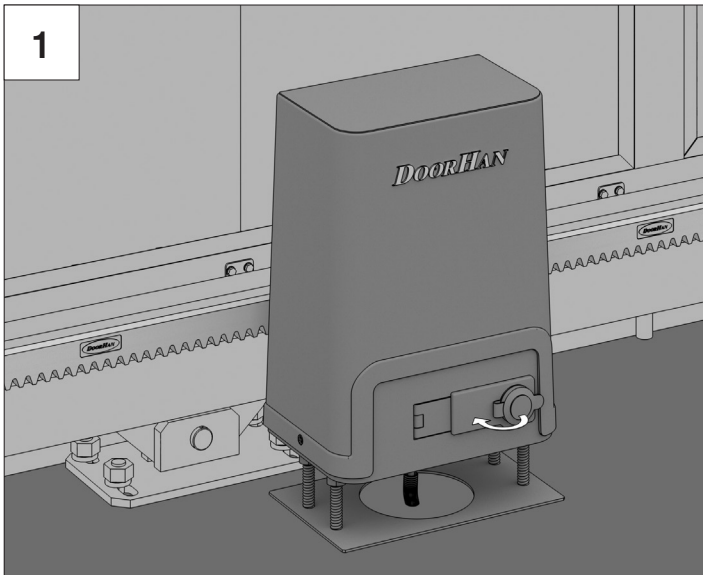

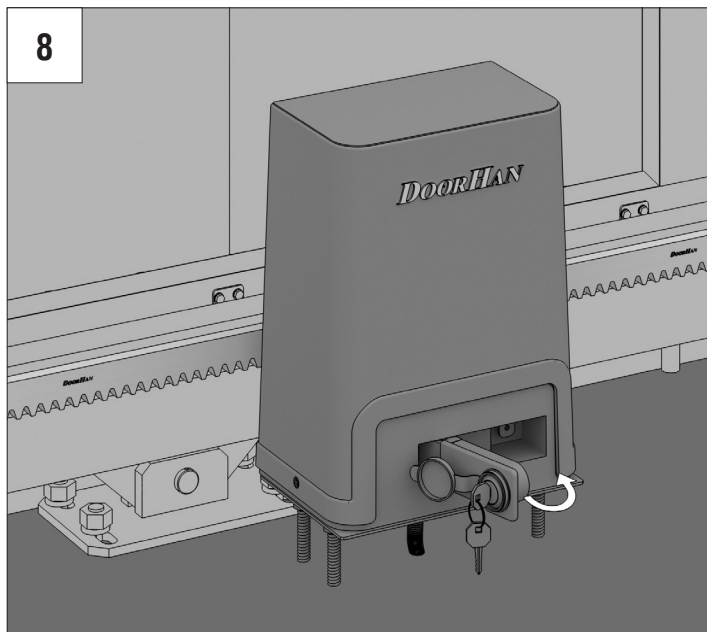
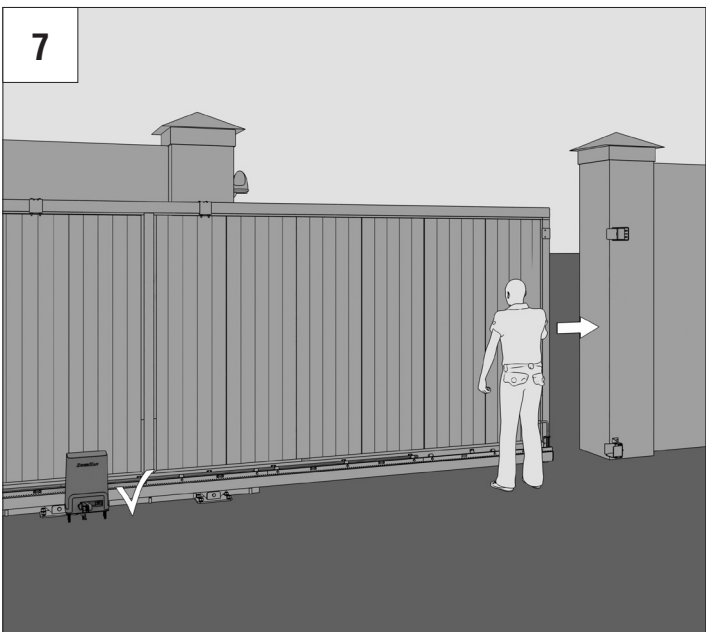
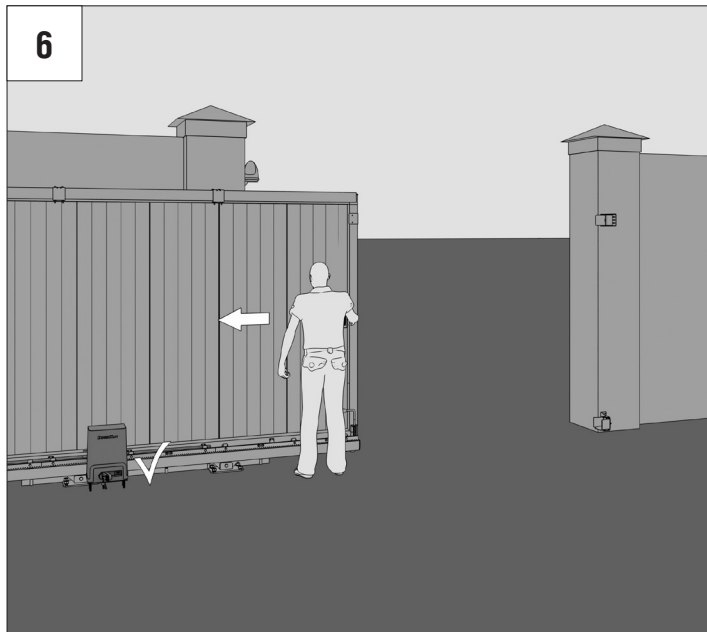
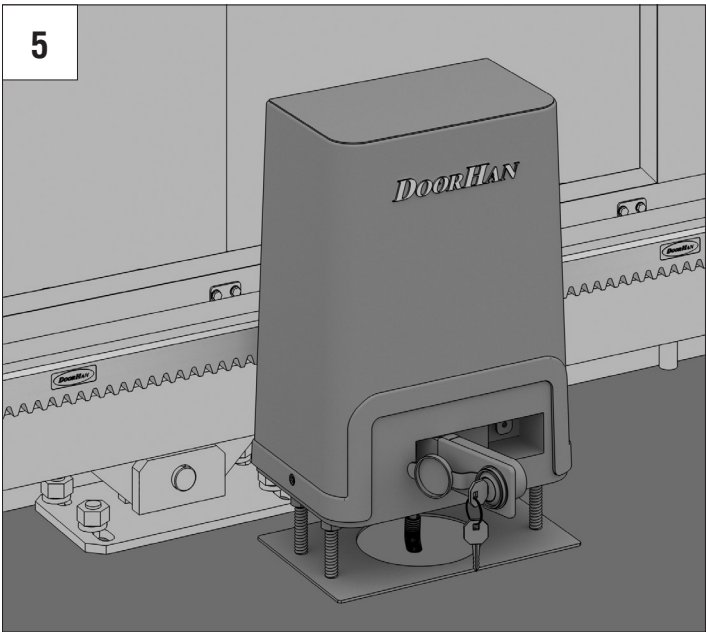
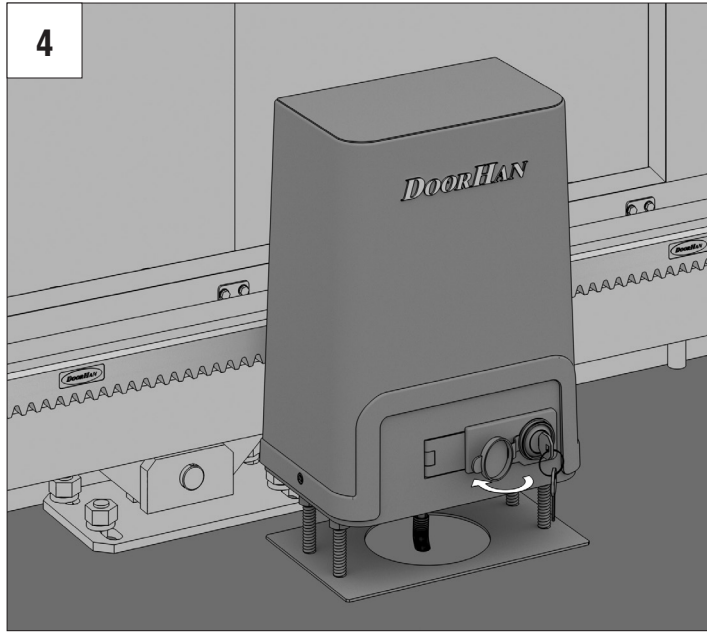
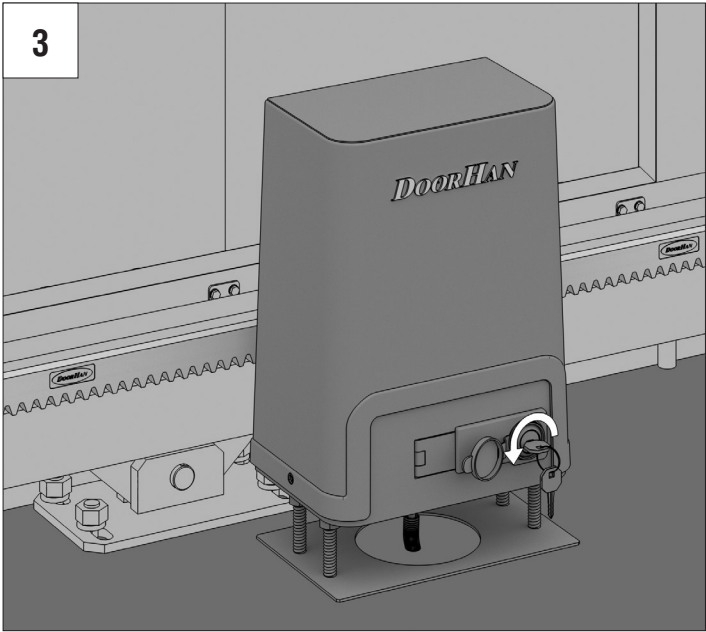

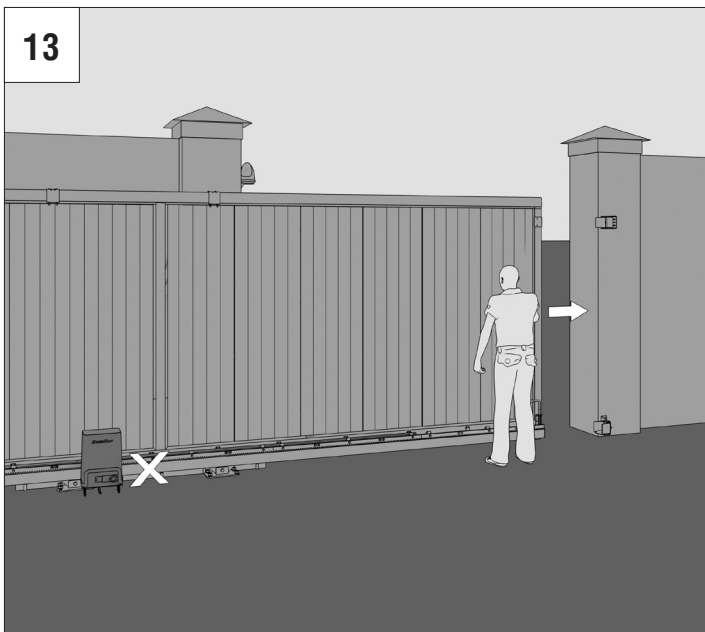
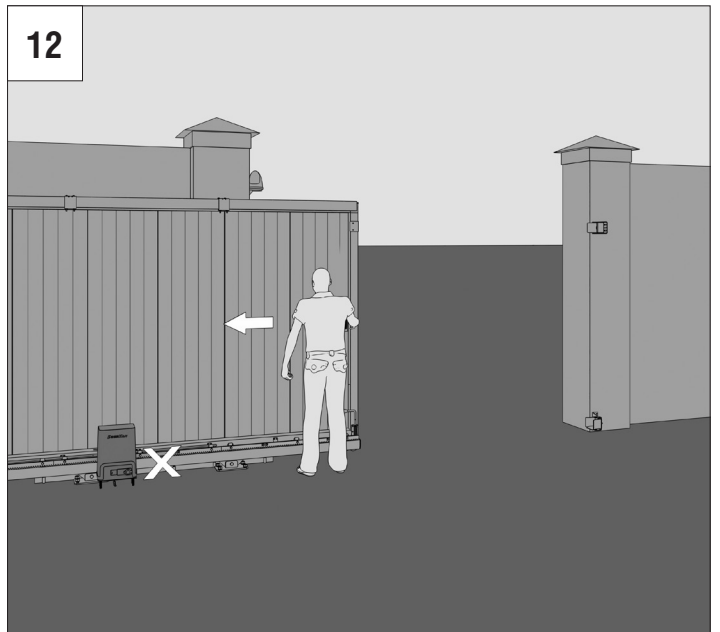
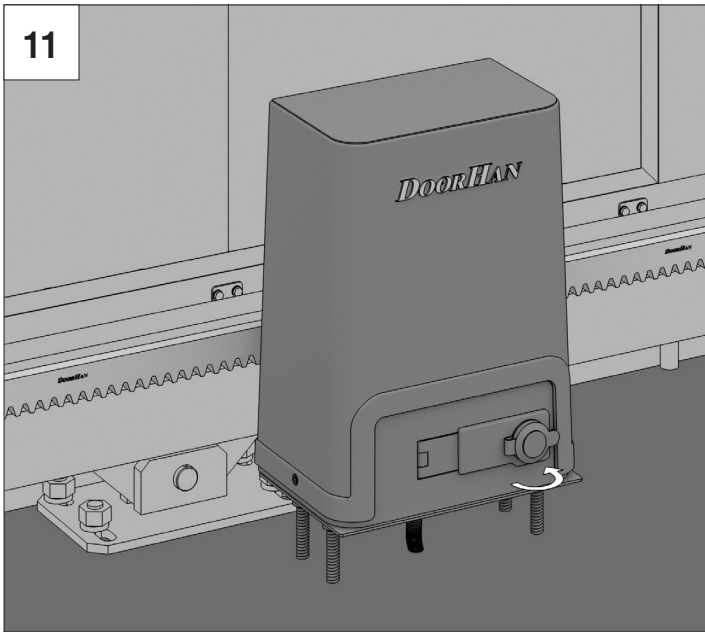
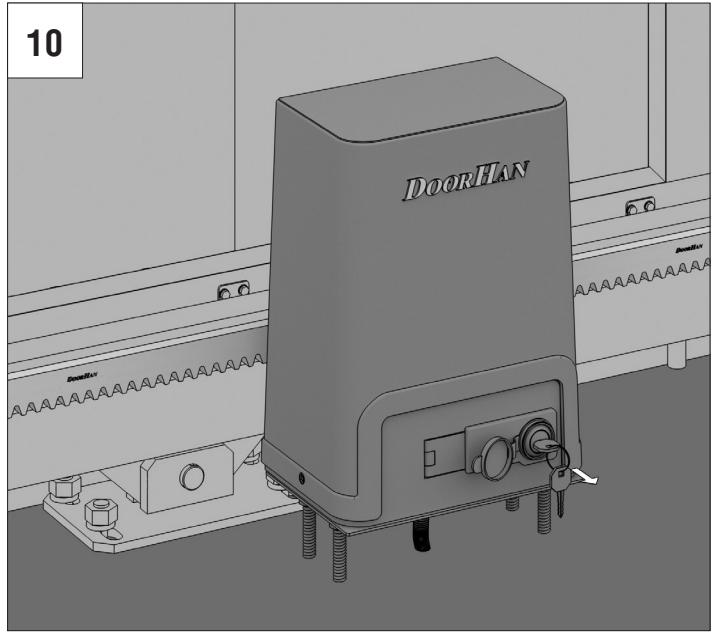
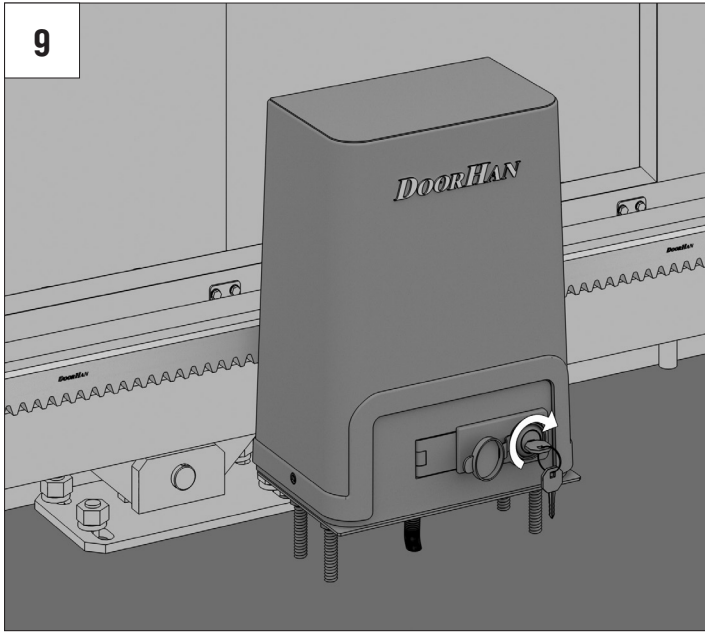

***DOORHAN***<sup>®</sup>



Концерн DoorHan благодарит вас за приобретение нашей продукции. Мы надеемся, что вы останетесь довольны качеством данного изделия.

По вопросам приобретения, дистрибьюции и технического обслуживания обращайтесь в компанию ТЕХНОГРАД:

г. Минск, а/г Озерцо, ул. Дзержинского, д. 26а, 3-й этаж

Телефоны:  
+375175174470 (телефон / факс)  
+375447752155 (A1 / Viber)  
+375295318672 (МТС)

E-mail: [info@technograd.by](mailto:info@technograd.by)  
[www.technograd.by](http://www.technograd.by)